

TYPICAL



GC6710A SERIES INTEGRATED DIRECT DRIVE LOCKSTCH SEWING

MACHINE WITH THREAD TRIMMER

INSTRUCTION BOOK

※NOTE

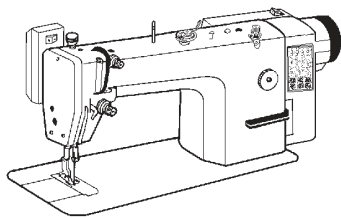

The sewing machine should always be lubricated and the oil supply replenished before it is used for the first time, and also replenished it is used for the first time, and also after long periods of non-use use only the lubricating oil our company. then lift the presser foot and run the machine at a low speed of 3000 spm to check oil distributing condition through oil check window. When lubricating is normal, keep the machine run in at this speed for 30 minutes, then increase the running speed gradually. After one month run-in operation, the machine can be run at the max speed under normal working condition.

2. ROTATING HOOK OIL AMOUNT ADJUSTMENT

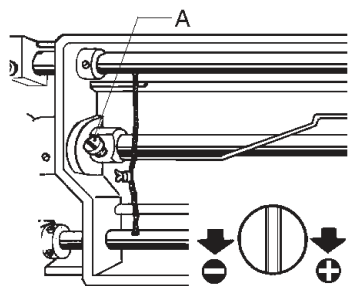

Adjust the oil amount of the rotating hook by turning the oil amount adjusting screw (A). Turn the screw (A) clockwise (in the "+" direction) to increase the oil amount; turn it counter-clockwise (in the "-" direction) to decrease the oil amount.

4. NEEDLE INSTALLATION

Turning the balance wheel to lift the needle bar to the upper end of its stroke. Loosen the needle clamp screw while keeping the long groove of the needle leftward, fully insert the needle shank up to the bottom of the needle socket, then tighten the needle clamp screw.

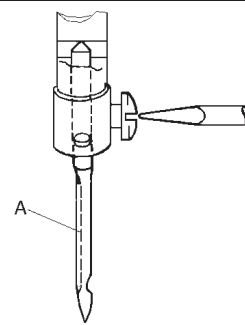

5. CONNECTION OF THE CLUTCH LEVER WITH THE PEDAL

(1) Install speed governor A, link speed governor A and pedal B with tie bar, keep tie bar C vertical.
(2) The optimum tilt angle of pedal is approximately 15 deg.

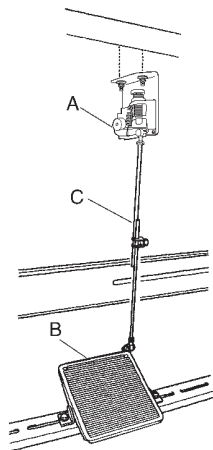

6. ADJUST THE OPENING TIME OF THE TENSION DISCS

Within the presser foot lift range, the opening time of the tension discs can be adjusted as follows:

(1) Remove the rubber plug from the back of the arm and Loosen the screw (A) of the knee lift level (left)
(2) Move the tension releasing cam (D) leftward for earlier opening or rightward for later opening. It will facilitate the adjustment if putting a lifting high block under the presser foot lift.

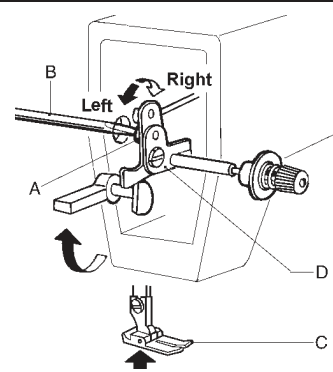

7. THREADING

To thread the needle thread, raise the needle bar to the upper end of its stroke, lead the thread from the spool and perform Threading as shown in . To draw the bobbin thread, hold the end of the needle thread and turn the balance wheel to lower the needle bar and then lift it to its highest position. Pull the ends of needle thread and bobbin thread forward under presser foot.

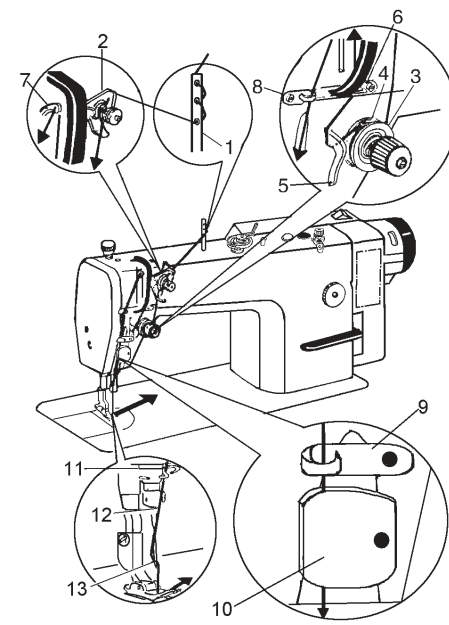

8. WINDING THE LOWER THREAD

Turn on the power switch. Place the bobbin (A) onto the bobbin winder shaft (B). Wind the thread several times around the bobbin (A) in the direction indicated by the arrow. Push the bobbin (A) in the direction of the arrow. Raise the presser foot with the lifting lever. Depress the treadle. Lower thread winding will then start. Once winding of the lower thread is completed, the bobbin presser arm (C) will return automatically. After the thread has been wound on, remove the bobbin and cut the thread with the knife (D).

NOTE:

- Loosen the screw (E) and move the bobbin presser (C) to adjust the amount of thread wound onto the bobbin.
- The amount of thread wound onto the bobbin should be a maximum of 80% of the bobbin capacity.

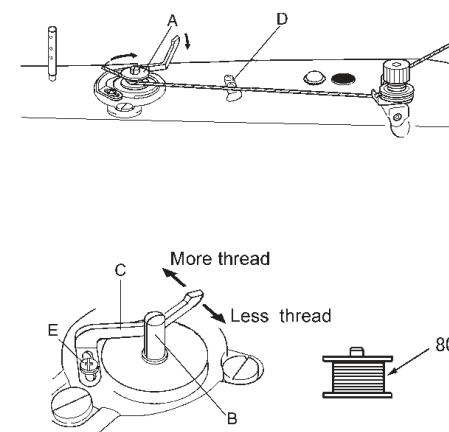

9. ADJUST THE PRESSURE OF PRESSER FOOT

Pressure of the presser foot is adjusted in accordance with thickness of materials to be sewn.

First loosen the lock nut (A), for heavy materials, turn the pressure regulating thumb screw as shown in Fig.(a) to increase the pressure, while for light materials, turn the pressure regulating thumb screw as shown in Fig.(b) to decrease the pressure, then tighten the lock nut (A). The pressure of the presser foot is recommended to be less as long as normal feeding is ensured.

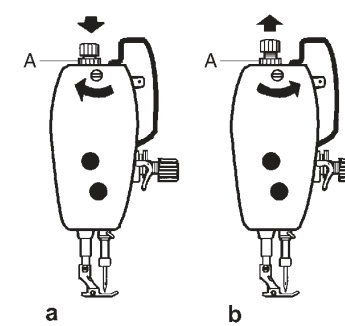

10. THREAD TENSION ADJUSTMENT

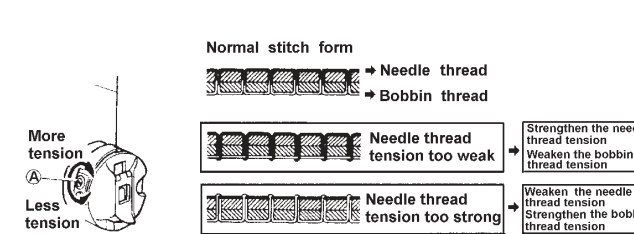

Thread tension should be determined in accordance with the stitch obtained by adjusting the tension of the bobbin thread and needle thread.

The tension of the bobbin thread: to be adjusted by turning the tension spring regulating screw of the bobbin case. After adjusting, insert the bobbin into the bobbin case and hold the end of the thread from the bobbin case to hang the bobbin case. If the bobbin case falls slowly and evenly, the proper tension of the bobbin thread is obtained.

The tension of needle thread: to be adjusted by turning the thumb nut.

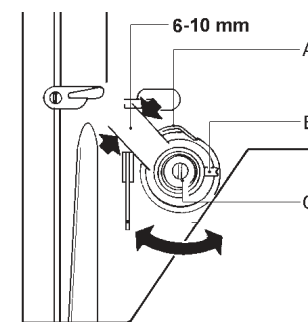
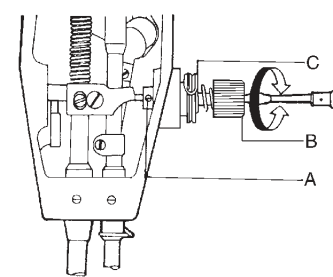

The stroke of the thread take-up spring runs from 6mm to 10mm, when sewing very thin fabrics, reduce the thread take-up spring tension and increase the thread take-up spring stroke, where as increase the thread take-up spring tension and reduce the thread take-up stroke when sewing very thick fabrics.

Adjusting the thread take-up spring tension: First loosen the set screw (A), Turn the tension stud (B) counter-clockwise to decrease the tension of the thread take-up spring (C) to zero. Then turn the tension stud (B) clockwise till the spring (C) comes to the notch of the tension regulating bushing, and again turn the tension stud (B) halfway back (counter clockwise). After the adjustment, tighten the set screw (A).

Adjusting the thread take-up spring stroke: loosen the set screw (B) turn the stud (C) clockwise to increase the stroke or turn stud (C) counter-clockwise to decrease the stroke after the adjustment. tighten the set screw (B).

11. ADJUST THE SYNCHRONIZATION OF THE NEEDLE WITH ROTATING HOOK

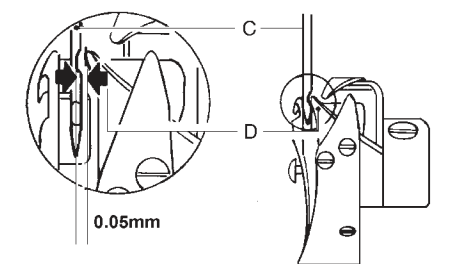
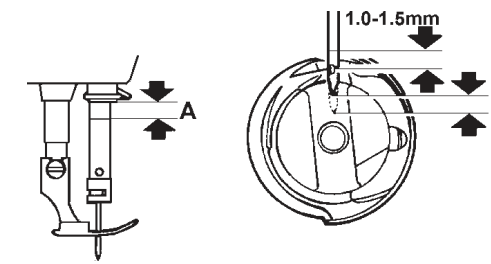

When lifting the needle bar from its lowest position of the stroke to the distance A, the hook point D of the bobbin should align with the center line of the needle and be 1.0-1.5 mm above upper end of the needle eye (Fig.15)

The clearance between the bottom of the needle notch and the hook tip should be 0.05 mm.

12. ADJUSTMENT OF STITCH LENGTH AND REVERSE FEEDING

The stitch length can be adjusted by turning the dial knob (A). The figures on the face (B) of the dial show the stitch length in mm. The reverse feed level must be depressed by another hand while adjusting the stitch length (B). The reverse feeding start when the reverse feed lever (B) is depressed, the machine will feed forward again if the reverse feed level is released.

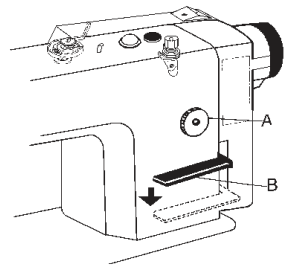

13. ADJUSTING THE POSITION OF FEED DOG AND NEEDLE

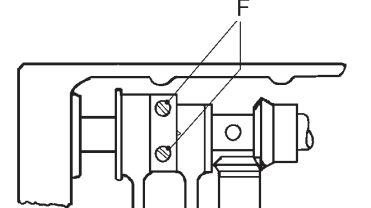
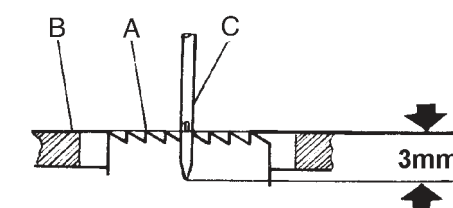

Turn the balance wheel, and lower Feed Dog (A). When the top of the feed dog is flush with needle Plate Surface (B), Needle Point (C) should be 3mm below the needle plate surface.

Loosen eccentric wheel screw, turn eccentric wheel and balance wheel separately to adjust the position of needle and feed dog. Then tighten the screw.

14. STITCH LENGTH ERROR ADJUSTMENT

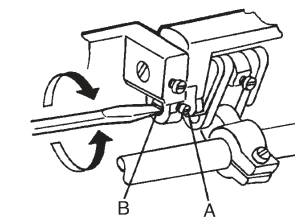

Loosen screw (A) to adjust the stitch length adjusting cam (B). Turn it rightward to narrow the stitch length as forward sewing, and widen it as reverse sewing; turn it leftward to widen the stitch length as forward sewing, and narrow it as reverse sewing.

15. FEED DOG HORI ONTALTY ADJUSTMENT

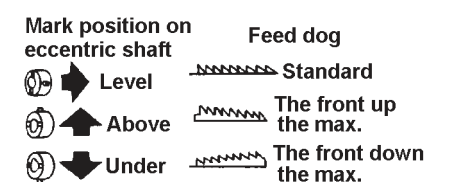

Heighten the front of feed dog to prevent fabric from wrinkling, lower the front of feed dog to prevent fabric from deflection, breaking of hook thread.

16. POSITION OF THE FIXED KNIFE AND LEFT KNIFE POINT

(1) The standard position is shown in the figure.
(2) If the size is larger than the standard, the knife will cut the 3 threads in the meantime or draw the thread out of the needle eye; if smaller, will cause cutting damage, so make sure to avoid that.

(3) As things mentioned above occur, adjustment is done by setting the fixed knife support or the fixed knife (B).

A-the blade B-Fixed knife C-the knife (left)

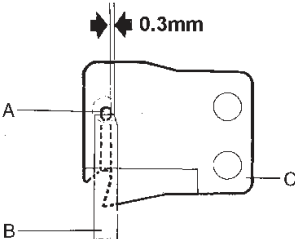

17. POSITION OF THE CUTTER DRIVING SHAFT

(1) The Standard position is shown in the figure.
(2) When assemble it, Cutter Driving Shaft (G) should be first put in Cutter Driving Crank (A).
(3) Set Thread Cutting Cam Crank (D) on the cutter driving shaft with reference to the standard position.
(4) Set Stopper (F), make sure that there is no clearance between parts around the cutter driving shaft, and rotate steadily.

A-knife driving crank
B-spring end cover
C-spring
D-thread cutting cam crank
E-thread cutting cam crank 2
F-stopper
G-knife driving shaft

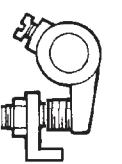
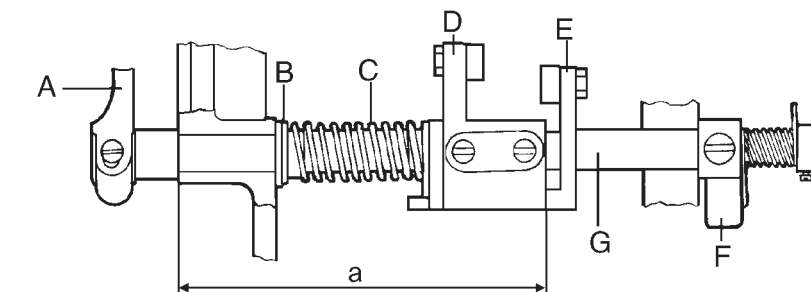

18.THE ELECTROMAGNET CORE STROKE

- (1)The standard stroke of the electromagnet core is 6mm.
 (2)The stroke can be adjusted with Positioning screw (A).
 B--thread cutting electromagnet holder
 C--thread cutting cam crank 2
 D--driving bar
 E--thread cutting electromagnet

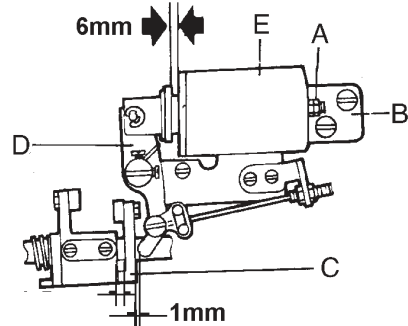

19.INSTALLING THREAD CUTTING CAM

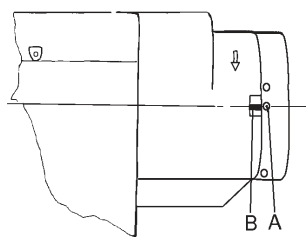

- (1)Align No.2 Positioning Mark (A) on the balance wheel with Positioning Mark (B) on the machine arm.

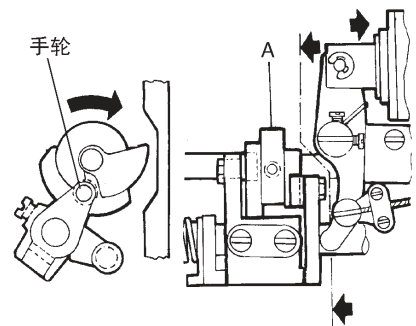

- (2)As the thread cutting electromagnet works, Thread Cutting Cam (A) run in normal rotating direction. Fix the cam when Cam (A) is engaged with Roller (B).

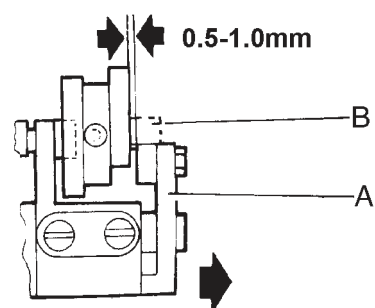

- (3)Stop the operation of the electromagnet, reset Cam Driving Crank (A), Cam (B) is separated from the en-gagement with the roller,the standard clearance is 0.5-1.0mm.

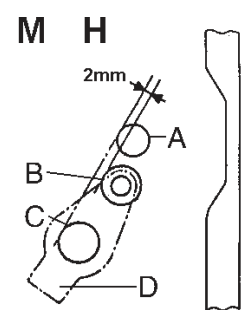

- NOTE:
 1.the figure shows the standard position of Cam Driving Crank (D) before operation.
 A--hook shaft B--roller C--cutter driving shaft

- 2.It may change the positions mentioned above to remove the stopper, then adjust with Screw (A), and readjust the above .

20.ADJUSTING KNIFE CUTTING ENGAGEMENT

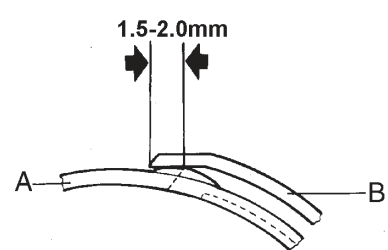

- ①When the electromagnet works, turn the machine, the movable knife (A) follows the motion of the thread cutting cam. The maximum degree of cutting engagement is 1.5-2.0mm (B--the fixed knife)
 ②Adjust the cutter driving crank if necessary.

21.ADJUSTING CUTTING PRESSURE

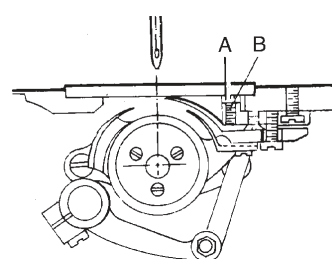

- (1)When cutting thick thread, increase the cutting force.
 (2)For adjusting cutting force, loosen Set Nut (A),and adjust Screw (B).

22.ADJUSTING NEEDLE THREAD TENSION

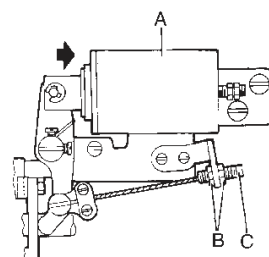

- There should be a clearance of 1mm between the two discs while the thread cutting electromagnet (A) is working.
 For adjustment, loosen Nut (B),and move soft thread (C).

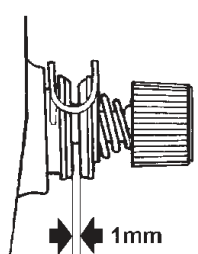

- Note: If the clearance is too small, the thread end left after cutting is too short and may easily go away from the needle eye; otherwise the tension is poor and affect the needle thread tension.

23.THREAD END REMAINS ADJUSTMENT

- To get the needle thread end remains properly, adjust Nut (A).
 Turn rightwrtd: get shorter
 Turn leftward: get longer

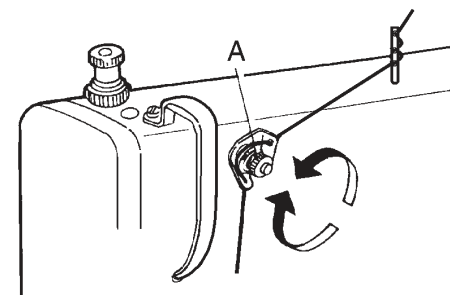

24.INSTALLING REVERSE STITCH ELECTROMAGNET(D3)

- Adjust the position of Electromagnet (A) properly to guarantee the flexiable connection of the magnet with the link lever and the convenient operation of Reverse Stitch Bar (B),then set with a screw.

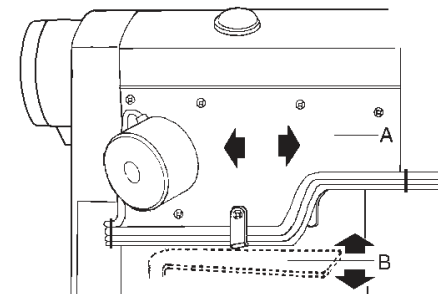

25.REVERSE STITCH NEEDLE SWITCH

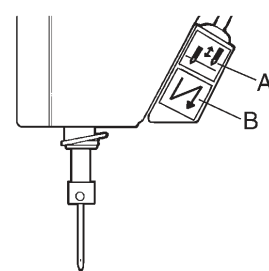

- For the double switch model:
 push button A, it can perform back tacking sewing push button B it can perform reverse sewing.

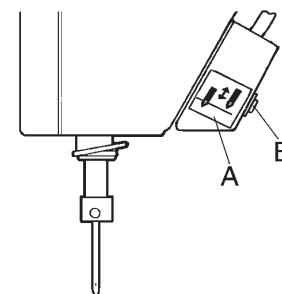

- For the single switch model:press switch A could change the needle position to up or down.
 open LED lamp by switch B.

26.HOOK BOBBIN CASE AND BOBBIN

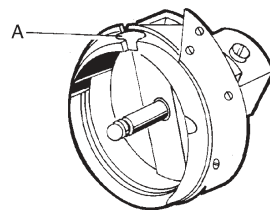

- 1.There is a thread groove (A) in the special hook for thread cutting sewing machine.

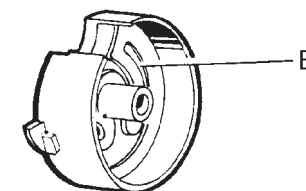

- 2.The bobbin case used in the machine should be with a spring (B) in its bottom, which prevents the bobbin from running without loading.

27.PERIODICAL CLEANING

- 1)Cleaning feed dog
 Remove the throat plate and clear off the dust and lint between feed dog tooth slots.
 2)Cleaning rotating hook
 Swing out the machine head and clean the hook.Wipe the bobbin case with soft cloth.
 3)Cleaning oil pump screen
 Swing out the machine head and clear off the dust and dirt on oil pump screen.

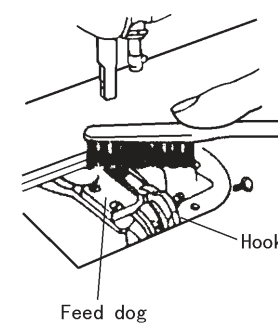

Feed dog

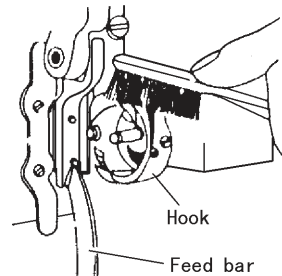

Hook
 Feed bar

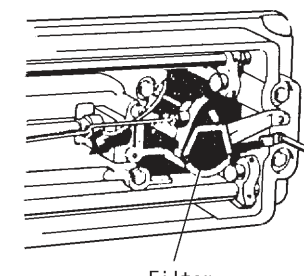

Filter

28.THREAD RETAINING DEVICE

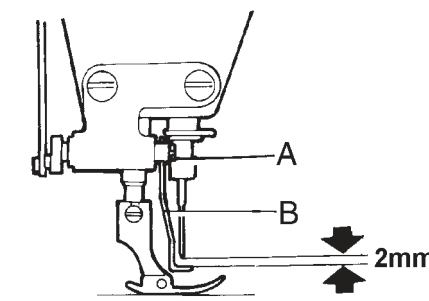

- 1.Thread Retainer Height
 (1) Standard height: 2 mm from the thread retainer as the needle in its highest position.
 (2) To adjust Thread Retainer (B), loosen Screw (A).

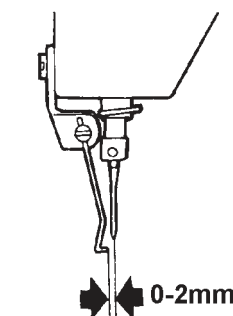

2. Thread Retainer Working position.
 (1) When the magnet move into the electromagnet completely, the standard distance between the thread retainer and the center of the needle should be 0-2 mm.
 (2)To adjust its position, loosen Screw (C), Screw (B), and adjust the position of Electro-magnet Asm(A).
 D--magnet

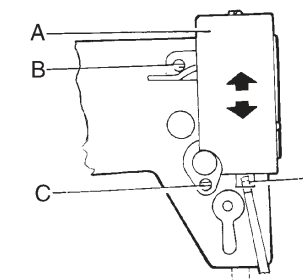

6710A series machine's main technical date

Item	model	M	H	B
Application		Commom materials	Thick materials	Thick materials
Sewing speed		4500 spm	3500 spm	3000 spm
Max. Stitch length		5mm	7mm	7mm
knee controlled Presser foot lifting height		13mm		
Rotating shuttle		Standard automatic oiling	Thick materials automatic oiling	Double materials automatic oiling
Needle		DBx1 11 # - 16 #	DPx5 18 # - 22 #	DPx5 18 # - 22 #

- When sewing at speeds of 3000 rpm or higher,set the stitch length to 5mm or less.

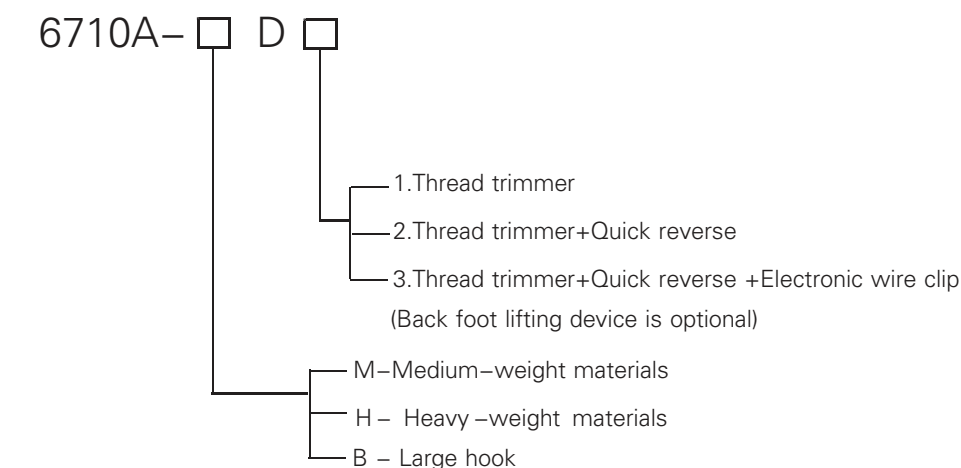

- Note :6710A-M/HD3C With Thread trimmer+Quick reverse+Thread wiper

TYPICAL



GC6710A SERIES INTEGRATED DIRECT DRIVE LOCKSTCH SEWING MACHINE

WITH THREAD TRIMMER

PARTS CATALOGUE

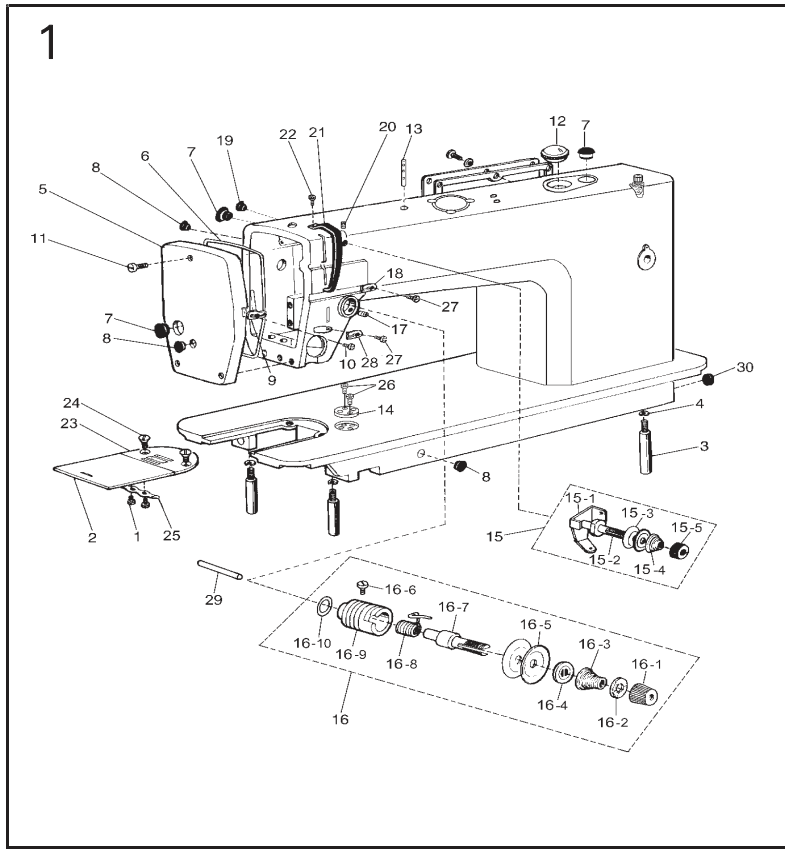

1. ARM AND BED MECHANISM

No.	Ref.No.	Description	Qt.		
			M	H	B
1	022170003	Screw	2	2	2
2	022170001	Slide plate	1	1	1
3	048100005	Leg	3	3	3
4	S150601004	Spring washer GB93-76 φ 6	3	3	3
5	238120001	Face plate	1	1	1
6	S150651047	O-type ring GB3452.1-92	1	1	1
7	022130003-V	Rubber plug (φ 19)	3	3	3
8	022130004-V	Rubber plug (φ 11.8)	2	2	2
9	022130005	Thread guide on face plate	1	1	1
	078130001	Thread guide on face plate			1
10	B040750494	Screw M3.5 x 6	1	1	1
11	022100004	Screw	1	1	1
12	022180001-V	Oil check window	1	1	1
13	108200009	Thread guide pole	1	1	1
14	057100008	Ruler plate	1	1	1
15	036240000-W	Clip line Assy	1	1	1
15-1	036240001	Pretension thread guide	1	1	1
15-2	036240002	Thread tension stud	1	1	1
15-3	022150003	Thread tension disc	2	2	2
15-4	036240003-d	Tension spring for pretension	1	1	1
15-5	036240004-W	Thread tension nut	1	1	1
16	124130000-W	Wire clamping device Assy	1		
	124100007-W	Wire clamping device Assy		1	1
16-1	124130001-W	Thread tension nut	1	1	1
16-2	022160010	Stop disc	1	1	1
16-3	124130002-d	Thread tension spring	1		
	048110001-d	Thread tension spring		1	1
16-4	022160004	Thread tension releasing disc	1	1	1
16-5	022160005	Thread tension disc	2	2	2
16-6	022160008	Screw	1	1	1
16-7	022160001	Screw	1	1	1
16-8	022160006	Thread take-up spring	1		
	048110002	Thread take-up spring		1	1
16-9	022160007	Thread tension regulator bushing	1	1	1
16-10	022160011	O-type ring	1	1	1
17	022100013-d	Set screw	1	1	1
18	022100014	Thread guide	1	1	1
19	022100015-V	Rubber plug (φ 8.8)	2	2	2
20	022100011-d	Set screw	1	1	1
21	BXF9768001	Thread take-up lever guard	1	1	1
22	022200004-d	Screw	1	1	1
23	124100005	Needle plate (B1.8)	1		
	165100101	Needle plate (Four rows B1.8)		1	1
	048100004	Needle plate (B2.0)	1		
	153100004	Needle plate (Four rows)	1		
	048100006	Needle plate (B2.6)		1	1
24	022100020	Screw	2	2	2
25	022170002	Slide plate spring	1	1	1
26	124100004	Screw	2	2	2
27	022130006	Screw SM3.57 x 6	2	2	2
28	BXF3839009	Thread guide	1	1	1
29	238100004	Thread tension releasing pin	1	1	1
30	022100016	Rubber plug (φ 27)	1	1	1

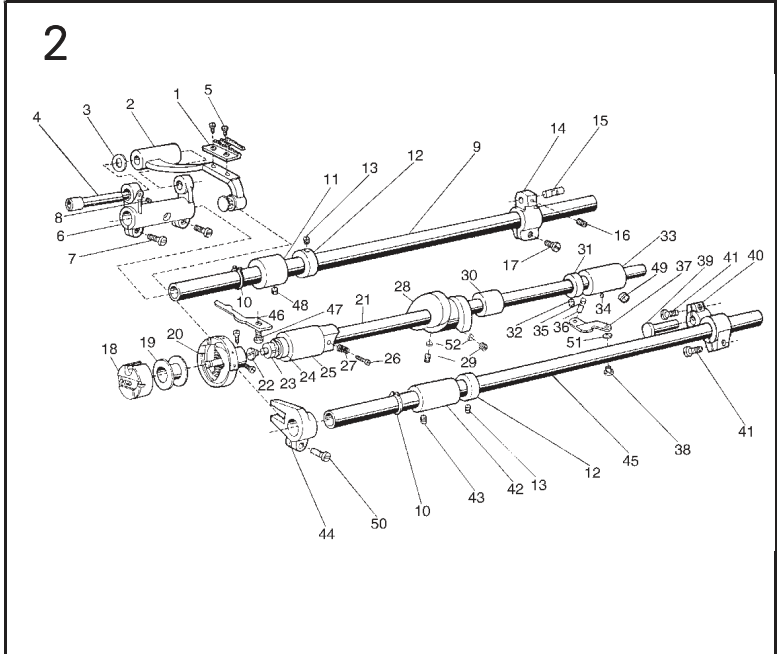

2. FEEDING AND FEED LIFTING AND ROTATING HOOK MECHANISM

No.	Ref.No.	Description	Qt.		
			M	H	B
1	022610003	Feed dog	1	1	1
	165400105	Feed dog		1	1
	165400102	Feed dog		1	1
2	036411000	Feed bar	1	1	1
3	022610006	Washer	1	1	1
4	036410002	Shaft for feed bar	1	1	1
5	022610004	Screw	2	2	2
6	022611001	Feed rock shaft crank	1	1	1
7	022612001	Screw	2	2	2
8	022200019	Screw	1	1	1
9	124600002	Feed rock shaft	1	1	1
10	S150617006	C-type stop ring 15	2	2	2
11	022600004	Bushing for feed rock shaft	1	1	1
12	022620001	Collar for feed rock shaft	2	2	2
13	022320002	Screw	4	4	4
14	036400003	Feed rock shaft crank(right)	1		
	114400001	Feed rock shaft crank(right)		1	1
15	036400204	Pin	1	1	1
16	036550005	Screw	1	1	1
17	022640003	Screw	1	1	1
18	03642	Bobbin case complete	1	1	1
	12042	Bobbin case complete		1	1
19	036400006	Bobbin	1	1	
	078400005	Bobbin			1
20	03643	Rotating hook complete	1		
	165420000	Rotating hook complete		1	1
	12041	Rotating hook complete			1
21	036440001	Hook shaft	1	1	1
	120400001	Hook shaft		1	1
22	022411001	Filter screw	1	1	1
23	022411002	Filter	1	1	1
24	036470001	Oil seal	1	1	1
25	036400010	Hook shaft bushing(left)	1	1	1
26	022400005	Oil adjusting screw	1	1	1
27	022400006	Coil spring	1	1	1
28	036450001	Thread cutting cam	1	1	1
29	B096339088	Screw	2	2	2
30	036400012	Hook shaft bushing(middle)	1	1	1
31	022420001	Collar for hook shaft	1	1	1
32	022200009	Screw	2	2	2
33	036460001	Hook shaft bushing (right)	1	1	1
34	022430002	Oil pipe for hook shaft bushing	1	1	1
35	036400015	Plunger	1	1	1
36	036400016	Plunger spring	1	1	1
37	022400010	Guide plate	1	1	1
	078400006	Guide plate		1	1
38	022820001	Screw	1	1	1
39	022600007	Hinge pin	1	1	1
40	036400017	Feed lifting rock shaft crank (R)	1	1	1
41	022600016	Screw	2	2	2
42	022600004	Bushing for feed lifting shaft (L)	1	1	1
43	022200002	Screw	1	1	1
44	036484001	Feed lifting fork	1	1	1
45	124600003	Feed lifting rock shaft	1	1	1
46	022400013	Hook positioner	1		
	048400002	Hook positioner		1	1
	078400003	Hook positioner			1
47	022400015	Screw	1	1	1
48	022200009	Screw	1	1	1
49	022200002	Screw	1	1	1
50	022640003	Screw	1	1	1
51	S150601004	Washer GB93-76 φ 6	1	1	1
52	165400001	Washer	2	2	2

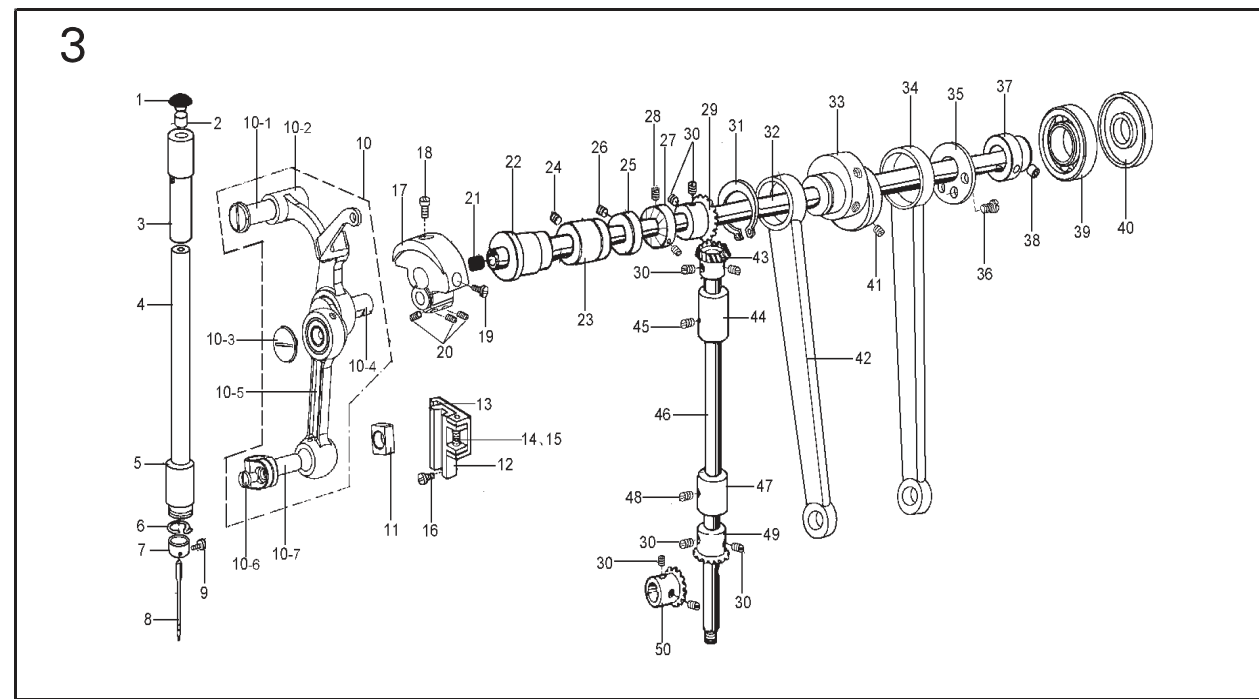

3. ARM SHAFT AND VERTICAL SHAFT THREAD TAKE-UP MECHANISM

No.	Ref.No.	Description	Qt.			No.	Ref.No.	Description	Qt.		
			M	H	B				M	H	B
						18	048220001	Needle bar crank	1	1	1
						18	022200007	Set screw	1	1	1
1	022200011-V	Rubber plug φ 8.8	4	4	4	19	022200006	Screw	1	1	1
2	022200010	Felt plug	1	1	1	20	BX87459009	Set screw M6 x 6	3	3	3
3	153200004	Needle bar bushing(upper)	1	1	1	21	022310002	Rubber plug φ 7.4X10	1	1	1
4	153200003	Needle bar	1			22	022300003	Arm shaft bushing(left)	1	1	1
	078200004	Needle bar		1	1	23	022300004	Needle bar bushing(middle)	1	1	1
5	153200005	Needle bushing(lower)	1			24	022200002	Screw	1	1	1
	124200006	Needle bushing(lower)		1	1	25	022320001	Collar for arm shaft	1	1	1
6	022230002	Thread guide	1	1	1	26	022320002	Screw	2	2	2
7	048200004	Thread guide for needle bar	1	1	1	27	207302000	Surge wheel	1	1	1
8	022200016	Needle DBX1 14#	1			28	S150212006	Screw GB77-2000 M5 x 6	2	2	2
	048200005	Needle DPX5 18#		1	1	29	Z0A180891	Bevel gear for arm shaft 33Z	1	1	1
	S150901003	Needle DPX5 22#		1	1	30	022220003	Set screw	8	8	8
9	022200017	Screw	1	1	1	31	022342001	Spacer	1	1	1
10	02221	Needle bar link asm	1			32	257200001	Arm shaft	1	1	1
	04821	Needle bar link asm		1	1	33	03634	Cloth feeding tooth lifting cam pack Assy	1	1	1
	07821	Needle bar link asm		1	1		114300001	Cloth feeding tooth lifting cam pack Assy		1	1
10-1	022210003	Hinge pin	1	1	1	34	036550002	Feed link	1	1	1
10-2	022210001	Thread connecting rod Assy	1			35	036300004	Spacer	1	1	1
	048210001	Thread connecting rod Assy		1	1	36	165330001	Screw	3	3	3
10-3	022210006	Screw	1	1	1	37	257200002	Bearing seat	1	1	1
10-4	022210004	Thread take-up crank	1			38	BX87459009	Set screw M6 x 6	3	3	3
	078210002	Thread take-up crank		1	1	39	S150801006	Bearing GB/T307-2005 6004ZZ	1	1	1
10-5	022212000	Needle bar link asm	1			40	238200004	Oil seal	1	1	1
	048210002	Needle bar link		1	1	41	022100013	Screw	2	2	2
10-6	022210009	Screw	1	1	1	42	022343001	Crank rod for lifting rock shaft	1	1	1
10-7	022210008	Needle rod joint	1	1	1	43	Z0A180892	Bevel gear for vertical shaft(upper)	1	1	1
11	022200020	Slide block	1	1	1	44	022300111	Vertical shaft bushing(upper)	1	1	1
12	036350001	Guide rail for slide block	1	1	1	45	022200002	Screw	1	1	1
13	036350002	Coupling head	1	1	1	46	022350001	Vertical shaft	1	1	1
14	036350003	Hinge pin	1	1	1	47	022300112	Vertical shaft bushing(lower)	1	1	1
15	036350004	Spring	1	1	1	48	022200002	Screw	1	1	1
16	022200019	Screw	2	2	2	49	Z0A180885	Bevel gear for vertical shaft(lower) 28Z	1	1	1
17	022220001	Needle bar crank	1			50	Z0A180886	Bevel gear for hook shaft 21Z	1	1	1

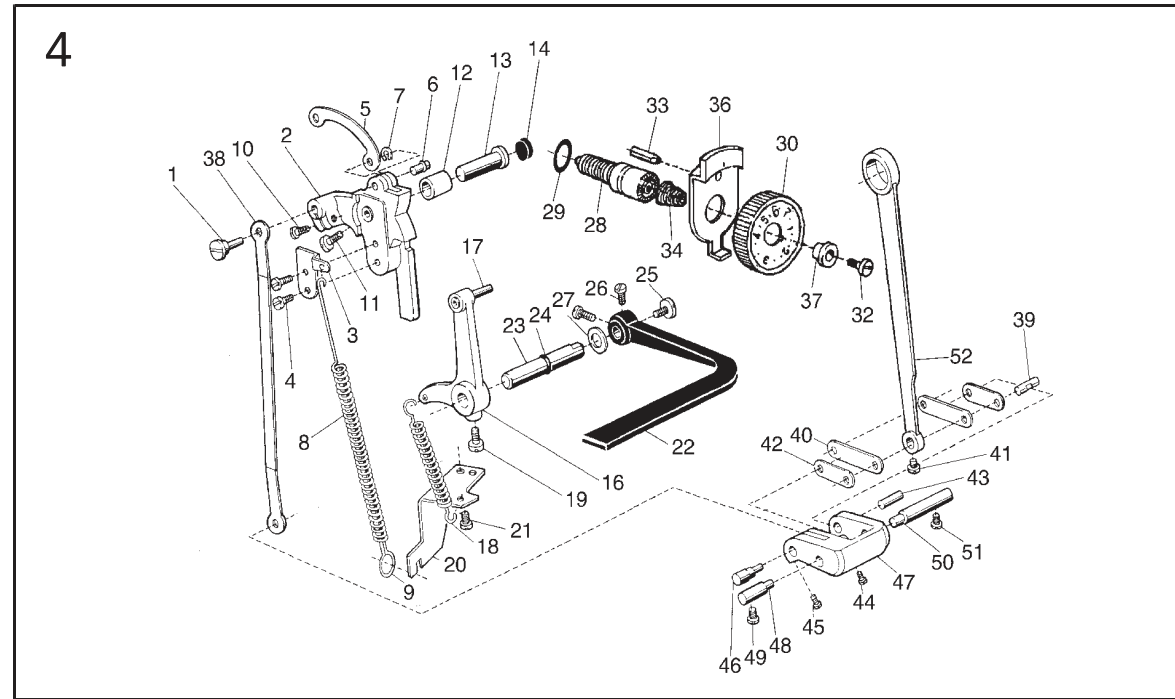
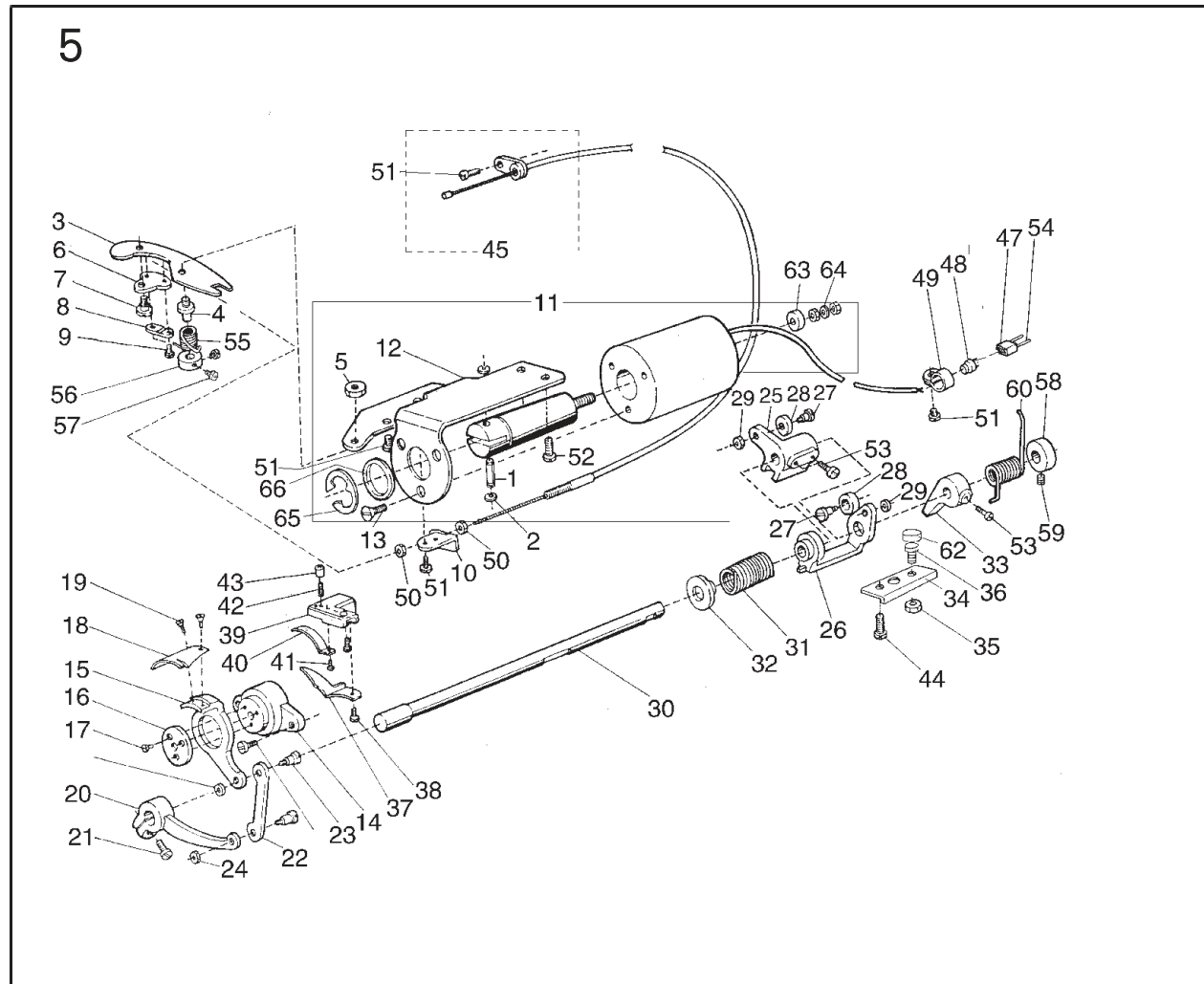

4. STITCH LENGTH REGULATING MECHANISM

No.	Ref.No.	Description	Qt.			No.	Ref.No.	Description	Qt.		
			M	H	B				M	H	B
						26	022540004	Screw	2	2	2
						27	022500011	Washer	1	1	1
1	036500001	Set pin	1	1	1	28	238300003	Screw bar	1	1	1
2	036510001	Feed regulator (D3)	1	1	1	29	124510003	O-type rubber ring	1	1	1
	057500001	Feed regulator		1	1	30	108500005	Dial 5mm	1		
3	036510002	Spring retainer	1	1	1		048520001	Dial 7mm		1	1
4	022200019	Screw	2	2	2	32	001A00003-d	Screw	1	1	1
5	036510003	Link (D3)	1	1	1	33	036500012	Pin	1	1	1
6	036510004	Pin (D3)	1	1	1	34	036500011	Spring	1	1	1
7	S150620004	Ring GB896-76 φ 4(D3)	1	1	1	36	238300010	Key for needle distance	1	1	1
8	036510005	Coil spring	1	1	1	37	036540004-d	Bushing	1	1	1
9	036510006	Spring holder	1	1	1	38	036550003	Stitch length regulating link	1	1	1
10	022640003	Screw	1	1	1	39	036400104	Crank link pin	1	1	1
11	022540004	Screw	1	1	1	40	036558002	Link(long)	2	2	2
12	238300001	Bushing for feed regulator	1	1	1	41	036550005	Screw	1	1	1
13	022500004	Pin shaft	1	1	1	42	036558001	Link(short)	2	2	2
14	238300002	Rubber plug (φ 16)	1	1	1	43	036550006	Pin(short)	1	1	1
16	036520001	Reverse sewing crank	1	1	1	44	036				

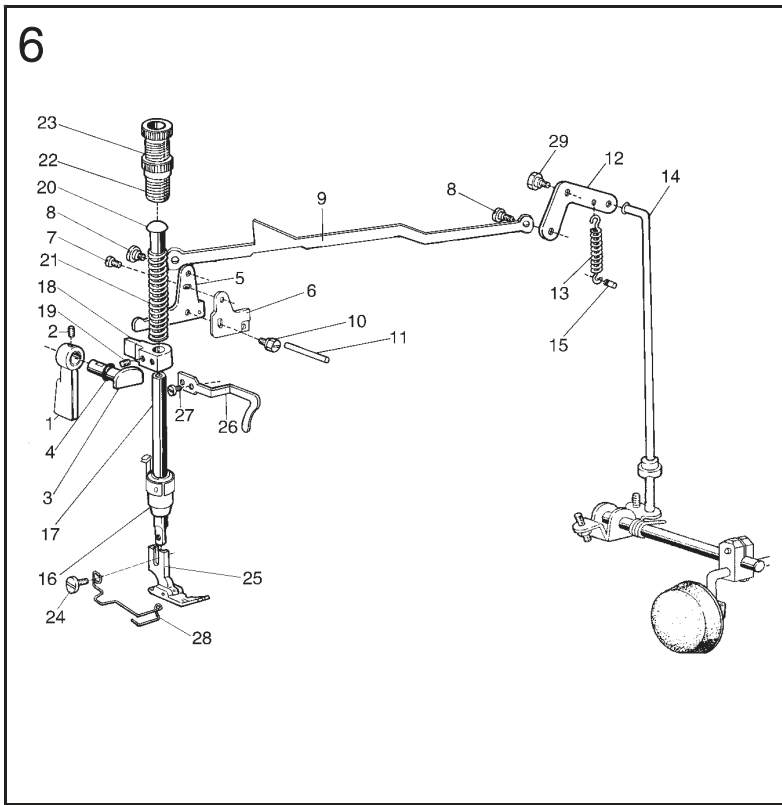

6. PRESSER FOOT MECHANISM

No.	Ref.No.	Description	Qt.		
			M	H	B
1	022710001--V	Presser bar lifter	1	1	1
2	B040600294	Screw	1	1	1
3	036620001	Presser bar lifting cam	1	1	1
4	S150651010	Oil seal GB3452.1-82(4.5 × 1.8G)	1	1	1
5	036631001	Knee lifter lever (left)	1	1	1
6	022722001	Tension relasing cam	1	1	1
7	022723001	Screw	1	1	1
8	022720002	Screw	2	2	2
9	238400002	Knee lifter rod	1	1	1
10	238Q10004	Knee lifter rod	1	1	1
11	022700005	Screw	1	1	1
12	238400003	Thread releasing pin	1	1	1
13	022730001	Knee lifter lever (right)	1	1	1
14	022730002	Coil spring	1	1	1
15	022730003	Knee lifter connecting rod	1	1	1
16	022700008	Pin for spring	1	1	1
17	022700009	Bushing for presser bar	1	1	1
18	022700010	Presser bar	1	1	1
19	238410000	Presser bar guide bracket	1	1	1
20	022100013	Screw	1	1	1
21	022700012	Presser bar spring guide	1	1	1
22	022700013	Presser bar spring	1	1	1
23	048700002	Presser bar spring	1	1	1
24	022750001--V	Thumb screw	1	1	1
25	022750002--V	Lock nut	1	1	1
26	022700015	Screw	1	1	1
27	022760000	Presser foot asm	1	1	1
28	048710000	Presser foot asm	1	1	1
29	238400004	Thread guide	1	1	1
30	022200004	Screw	1	1	1
31	057700002	Presser foot spring	1	1	1
32	022730004	Screw	1	1	1

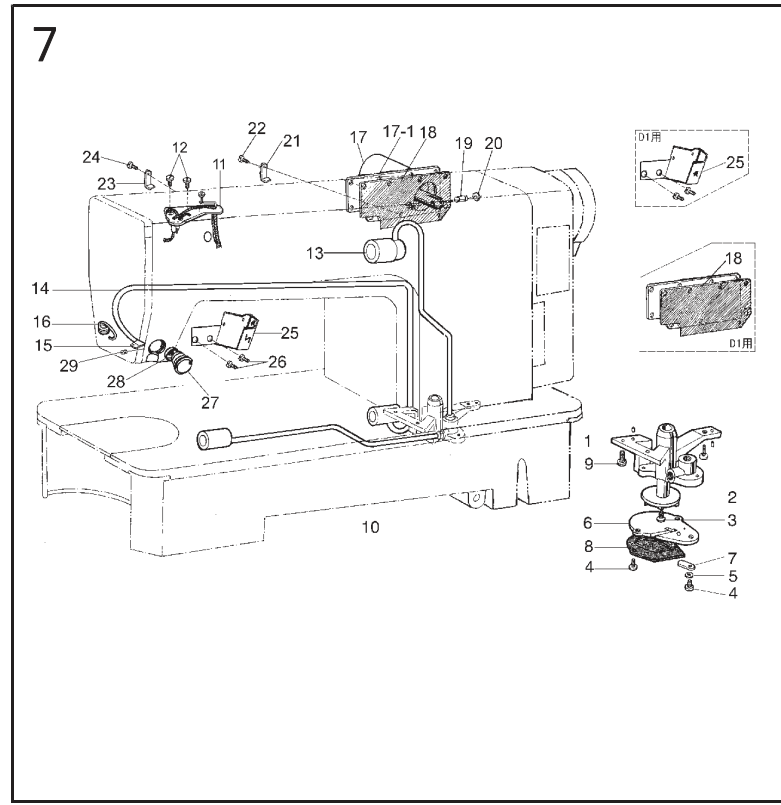

7. OIL PUMP AND REVERSE SEWING THREAD CLAMP MECHANISM

No.	Ref.No.	Description	Qt.		
			M	H	B
1	022800001	Oil pump	1	1	1
2	022800002	Oil pump impeller	1	1	1
3	022800003	Screw	1	1	1
4	022800004	Screw	3	3	3
5	S150601003	Springee washer GB93-76 φ 3	1	1	1
6	022800006	Oil pump fitting plate	1	1	1
7	078800001	Oil pump fitting plate	1	1	1
8	022800007	Oil adjusting plate	1	1	1
9	02281	Oil pump screen asm	1	1	1
10	022800009	Screw	3	3	3
11	022820N	Oil pump for hook shaft	1	1	1
12	022831	Oil braid fitting plate	1	1	1
13	022700015	Screw	2	2	2
14	022840N	Oil pump for arm shaft	1	1	1
15	078800002	Oil pump for arm shaft	1	1	1
16	022800014	Oil return pipe	1	1	1
17	022800015	Felt pouch for return oil filter	1	1	1
18	036A00002	Oil filter holder	1	1	1
19	238M70000	Electric-magnet and Side coverg (D3)	1	1	1
20	165820001--W	Side cover	1	1	1
21	036850001	Wahser	1	1	1
22	036800009	Pin (D3)	1	1	1
23	S150620004	Split retaining ring GB896-76 φ 4D3	2	2	2
24	238M10004	Wire clamp	1	1	1
25	022100006--D	Screw SM11/64*(4.37) × 40/10	8	8	8
26	BXF9722009--D	Wire clamp	1	1	1
27	022200004--D	Screw SM11/64*(4.37) × 40/5.5	1	1	1
28	238M30000	Double key with lamp down seam switch (D3)	1	1	1
29	238R51000	Single key with lamp down seam switch (D1)	1	1	1
30	022200019--D	Screw SM11/64*(4.37) × 40/8	2	2	2
31	238M20000	Clip line electromagnet assy	1	1	1
32	238N20002	Oil cover	1	1	1
33	S150212027	Screw GB77-85 M3 × 4	1	1	1

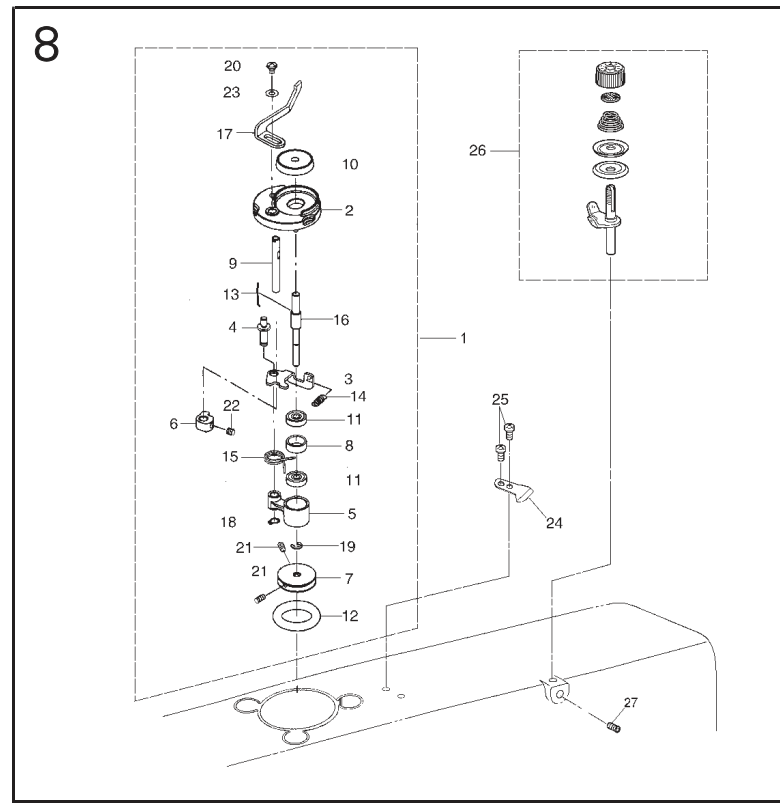

8. BOBBIN WINDER MECHANISM

No.	Ref.No.	Description	Qt.		
			M	H	B
1	207107000--W	Bobbin winder complete	1	1	1
2	207107004	Bobbin winder support	1	1	1
3	207107014	Bobbin winder lever	1	1	1
4	207107012	Bobbin winder lever shaft	1	1	1
5	207107006	Bobbin winder crank	1	1	1
6	207107011	Bobbin winder cam	1	1	1
7	207107008	Bobbin winder wheel	1	1	1
8	207107007	Bear bushing	1	1	1
9	207107010	Bobbin winder cam shaft	1	1	1
10	207107003	Bobbin support	1	1	1
11	S150801018	Bear GB/T307-2005 6205ZZNR	2	1	1
12	207107009	Rubber ring	1	1	1
13	207107002	Spring	1	1	1
14	207107005	Spring	1	1	1
15	207107013	Spring	1	1	1
16	207107001	Bobbin winder shaft	1	1	1
17	207107015	Wrench	1	1	1
18	W120607001	Retaining ting C6	1	1	1
19	B062060768	Retaining ting E4	1	1	1
20	S150237046	Screw M4X5	1	1	1
21	S150633007	Waher plain 4	1	1	1
22	S150212013	Screw GB77-2000 M5 × 5	1	1	1
23	B084060874	Screw M4X6	2	1	1
24	001100009	Knife	1	1	1
25	022830004	Screw SM3.57	2	2	2
26	BXF9116009--W	Thread tension complete(Small)	1	1	1
27	022200009	Screw	1	1	1

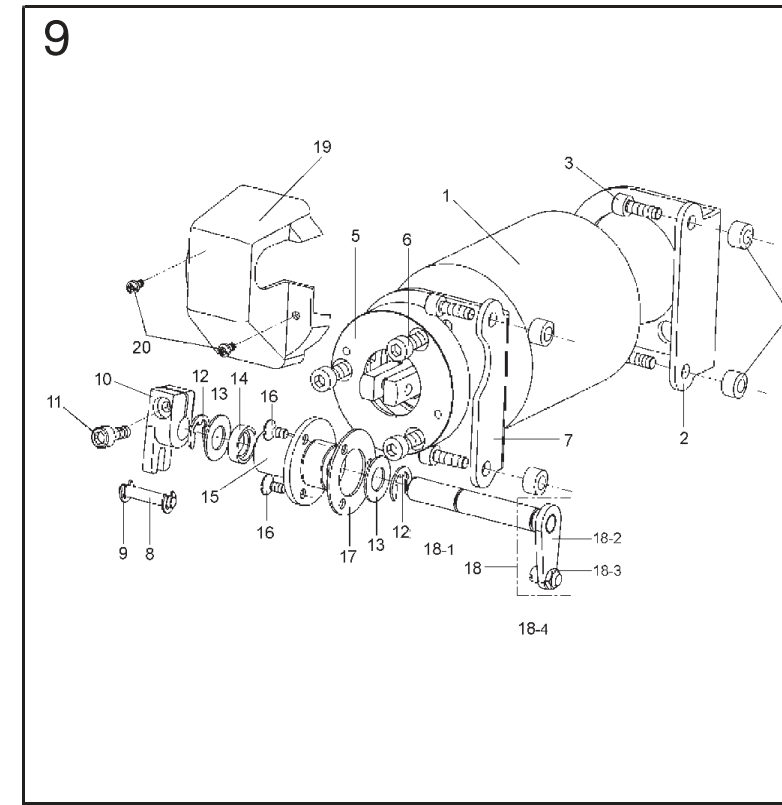

9. AUTOMATIC FOOT LIFTER MECHANISM

No.	Ref.No.	Description	Qt.		
			M	H	B
1	238Q20000	P-foot lifter solenoid assy	1	1	1
2	BXF9774009	Solenoid base L	1	1	1
3	S150209092	Screw GB70-85 M5 × 16	4	4	4
4	238Q10001	Cushion block	4	4	4
5	BX94481959	Solenoid stopper	1	1	1
6	S150209056	Screw GB70-85 M6 × 16	3	3	3
7	BXF9775009	Solenoid base R	1	1	1
8	BX94470059	Pin	1	1	1
9	B062060768	Retaining ring E4	2	2	2
10	BXF9772009	Presser foot lifter arm	1	1	1
11	B048509694	Screw M5 × 14	1	1	1
12	B062020768	Retaining ring E8	2	2	2
13	BX80754009	Flat Washer 10	2	2	2
14	S151099113	Seal G 10 × 14 × 3-B	1	1	1
15	238Q10002	Shaft sleeve	1	1	1
16	S150202034	Screw M4 × 8	3	3	3
17	238Q10003	Sealing gasket	1	1	1
18	238Q12000	Knee lifter shaft assy	1	1	1
18-1	238Q12001	Knee lifter shaft	1	1	1
18-2	260151002	Connecting plate	1	1	1
18-3	B089500794	Nut M5	1	1	1
18-4	260151003	Screw M5	1	1	1
19	BX94467001	Cover	1	1	1
20	S150216050	Screw GB818-85 M3.5 × 6 Z.H	2	2	2

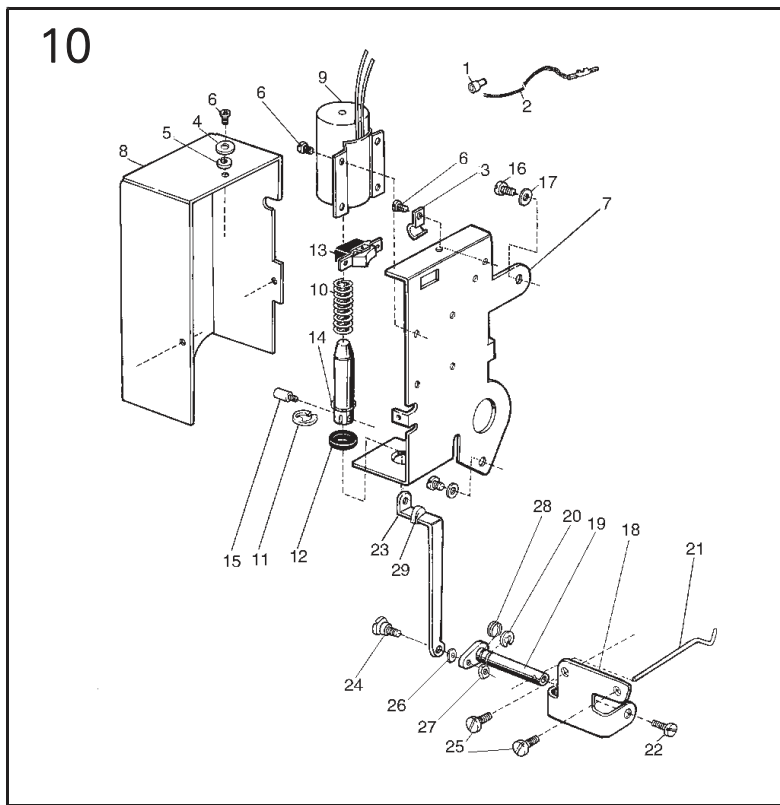

10. WIPER MECHANISM (FOR M/HD3C)

No.	Ref.No.	Description	Qt.		
			M	H	B
1	036910001	Wire connector	1	1	1
2	198000009	Wire	1	1	1
3	036910003	Cord clamp	1	1	1
4	S150607007	Washer3 GB97-76 φ 3	8	8	8
5	S150601003	Washer3 GB93-76 φ 3	8	8	8
6	S150216011	Screw GB818-76 3 × 6	8	8	8
7	036910004	Solenoid bracket	1	1	1
8	036910005	Cover for wiper mech	1	1	1
9	036910006	Solenoid for wiper	1	1	1
10	036910007	Coil spring	1	1	1
11	S150620003	Retaining ring GB896-76 φ 9	1	1	1
12	036910008	Rubber ring	1	1	1
13	036910009	Switch for wiper	1	1	1
14	036910010	Washer	1	1	1
15	036900002	Screw	1	1	1
16	022510004	Screw	2	2	2
17	036900003	Washer	2	2	2
18	036920001	Wiper bracket	1	1	1
19	036921008	Wiper shaft asm	1	1	1
20	S150620004	Retaining ring GB896-76 φ 4	2	2	2
21	036920003	Wiper	1	1	1
22	022610004	Screw	1	1	1
23	036920004	Link	1	1	1
24	036921007	Shaft	1	1	1
25	036900005	Screw	2	2	2
26	036921006	Washer	1	1	1
27	S150503014	Nut GB/T6170-2000 M3	1	1	1
28	036921005	Washer	1	1	1
29	165900001	Rubber washer	1	1	1

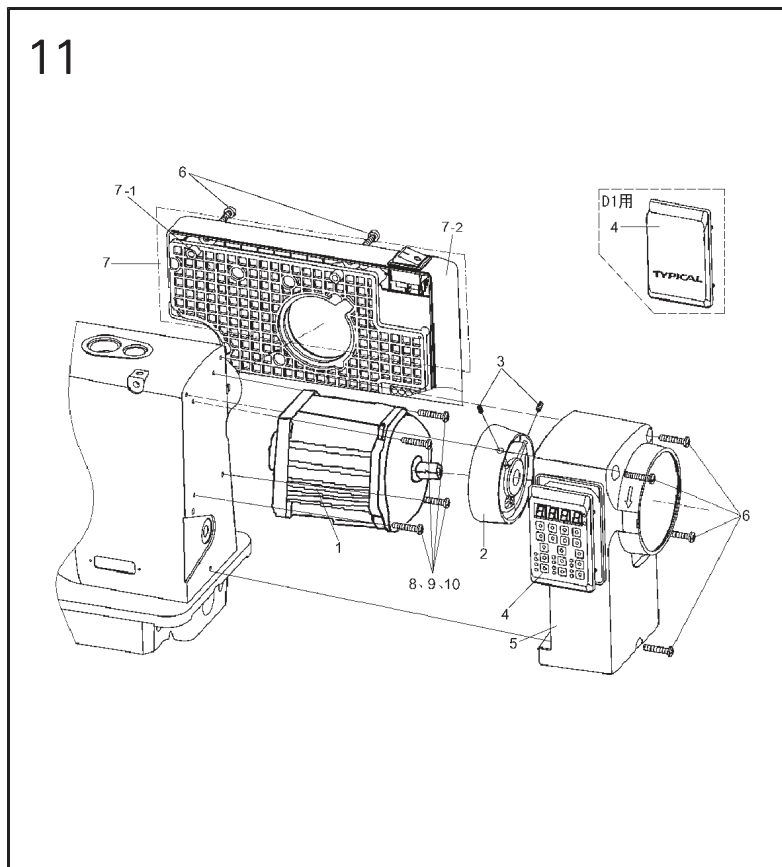

11. MOTOR CONTROL MECHANISM

No.	Ref.No.	Description	Qt.		
			M	H	B
1	238M42000	Motor	1	1	1
2	238M51000	Motor	1	1	1
3	238710001	Hand wheel	1	1	1
4	S150215001	Screw GB/T80-2000 M5 × 8	2	2	2
5	238M41000	Operation plateasm (MD3)	1	1	1
6	238R22000	Operation plateasm (MD1)	1	1	1
7	238M10001	Motor cover	1	1	1
8	S150216033	Screw GB818-85 M5 × 25 ZH	7	7	7
9	238M43000	controller asm	1	1	1
10	238M43001	Cooling plate	1	1	1
11	238M43002	Circuit board cover	1	1	1
12	B048509294	Screw M5 × 15	4	4	4
13	B082050864	Spring Washer 5	4	4	4
14	B084050974	Flat Washer S5	4	4	4

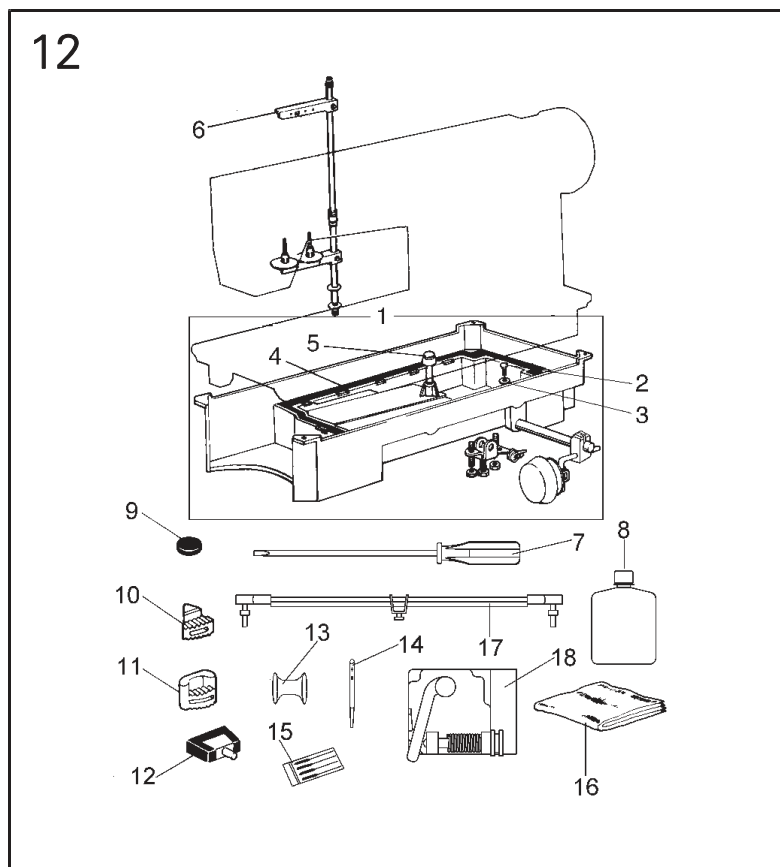

12. OIL RESERVOIR AND ACCESSORIES

No.	Ref.No.	Description	Qt.		
			M	H	B
1	036111000	Oil reservoir asm	1	1	1
2	022910002	Screw	1	1	1
3	022910003	Washer	1	1	1
4	22T9-001A5	Oil gasket	1	1	1
5	165F01001	Knee lifter lifting pin	1	1	1
6	006F00030--W	Thread spool asm	1	1	1
7	W050102068	Screw driver(big)	1	1	1
8	W060302087	Oil pot	1	1	1
9	W060401017	Magnet block	1	1	1
10	022900009--V	Cushion(B)	2	2	2
11	022900010--V	Cushion(S)	2	2	2
12	02299	Hinge with rubber cushion	1	1	1
13	036400006	Bobbin	2	2	2
14	108200009	Thread guide pole	1	1	1
15	022200016	Needle DBX1 14#	1	1	1
16	048200005	Needle DPX5 18#	1	1	1
17	S150901003	Needle DPX5 22#	1	1	1
18	W060302058	Machine head cover	1	1	1
19	238C15000	Rod assy	1	1	1
20	238M45000	Governor	1	1	1

XI'AN TYPICAL INDUSTRIES CO.,LTD.

Add: No.335 Taibai South Road, Xi'an,P.R.China-710068
Tel :+86-29-88279091 88279150
Fax :+86-29-88249715 88245215
E-mail:typical@chinatypical.com
Http:www.chinatypical.com